



17-4PH stainless steel, welding-sealed.
Suitable for electronic weighing equipments like belt scales, hopper scales, etc.

Capacity	Accuracy	Part number
20kg	C3	BM11-C3-20kg-3B-SC
30kg	C3	BM11-C3-30kg-3B-SC
50kg	C3	BM11-C3-50kg-3B-SC
100kg	C3	BM11-C3-100kg-3B-SC
200kg	C3	BM11-C3-200kg-3B-SC
350kg	C3	BM11-C3-350kg-3B-SC
500kg	C3	BM11-C3-500kg-3B-SC

Specifications

Accuracy Class	OIML R60 C3	NTEP III, III L	Temperature effect on zero (%FS/10C)	0.017
Rated output (mV/V)	2.0 ± 0.02		Temperature, Compensated (C)	-10~+40
Combined error (%FS)	0.02		Temperature, Operating (C)	-35~+65
Non-linearity (%FS)	0.017		Excitation, Recommended (V)	5-12(DC)
Non-repeatability (%FS)	0.01		Excitation, Max.(V)	18(DC)
Creep (%FS/30min)	0.02		Safe Overload (%FS)	150
Input Resistance (Ω)	460 ± 50		Ultimate Overload (%FS)	300
Output Resistance (Ω)	350 ± 3.5		Protection Class	IP 68
Insulation Resistance (MΩ)	≥ 5000(50VDC)		Cable Length (m)	3
Zero Balance (%FS)	1.0		Cable spec	4-wire shielded PU cable φ 5mm
Temperature effect on span (%FS/10C)	0.014			

Connections Green Input (+) Black Input (-) White Output(+) Red Output(-) Transparence (shield)

Outline Dimensions in mm(inches)

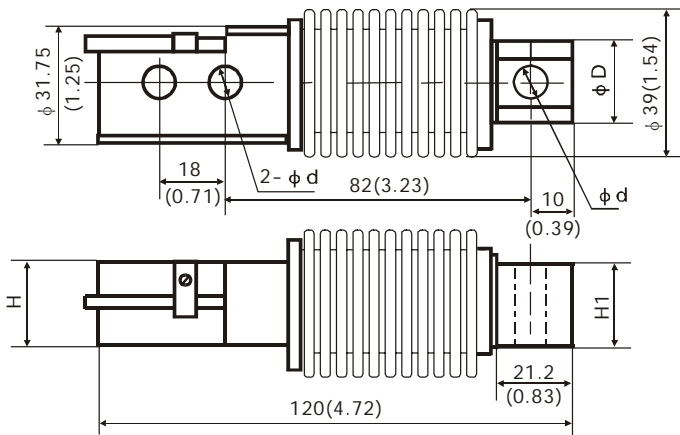

Dimensions Capacity (kg)	d	D	H1	H
20~200	8.2 (0.32)	23 (0.91)	20 (0.79)	20 (0.79)
350,500	10.3 (0.41)	24 (0.94)	19 (0.75)	20 (0.79)